



215994 E

2017-01

Processes



TIG (GTAW) Welding

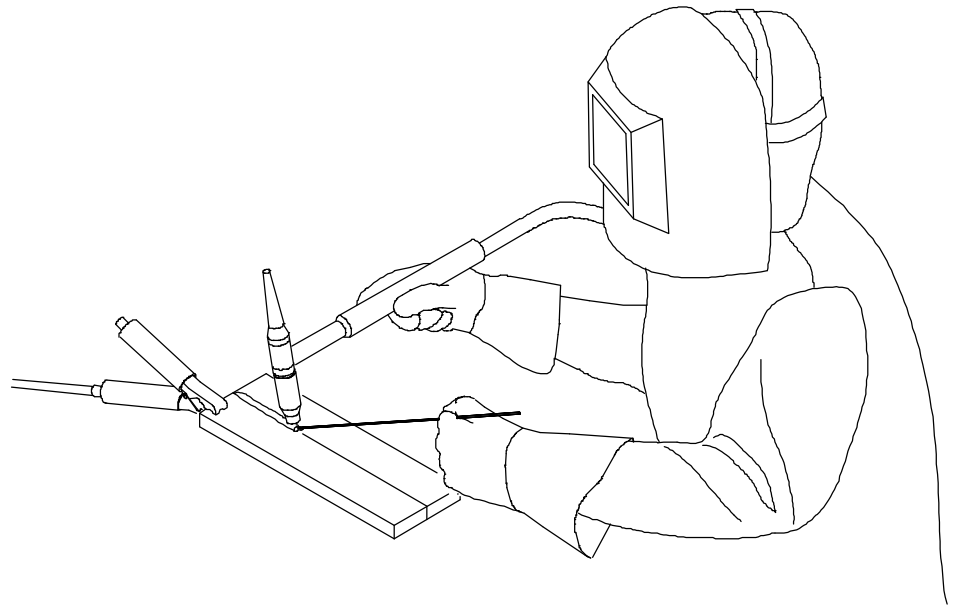

Guidelines For Gas Tungsten Arc Welding (GTAW)

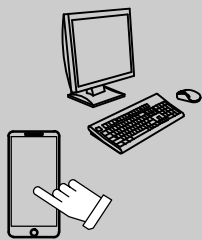

For product information,
Owner's Manual translations,
and more, visit

www.MillerWelds.com

TABLE OF CONTENTS

SECTION 1 – SAFETY PRECAUTIONS - READ BEFORE USING	1
1-1. Symbol Usage	1
1-2. Arc Welding Hazards	1
1-3. Additional Symbols For Installation, Operation, And Maintenance	3
1-4. California Proposition 65 Warnings	4
1-5. Principal Safety Standards	4
1-6. EMF Information	4
SECTION 2 – PRINCIPLES OF GAS TUNGSTEN ARC WELDING (GTAW)	5
2-1. Process Description	5
2-2. Selecting A GTAW Power Source	5
2-3. Typical GTAW Welding System	6
SECTION 3 – GAS TUNGSTEN ARC WELDING (GTAW) PROCEDURE	7
3-1. Typical GTAW Welding Set-Up	7
SECTION 4 – SELECTING AND PREPARING A TUNGSTEN FOR DC OR AC WELDING WITH INVERTER MACHINES	8
4-1. Selecting Tungsten Electrode (Wear Clean Gloves To Prevent Contamination Of Tungsten)	8
4-2. Preparing Tungsten Electrode For DC Electrode Negative (DCEN) Welding Or AC Welding With Inverter Machines	8
SECTION 5 – GTAW WAVEFORMS	9
SECTION 6 – ARC SHAPING CAPABILITIES	11
6-1. Arc Starting With Different Polarities	11
6-2. Balance Control	11
6-3. AC Frequency Adjustment Control	11
6-4. Independent Amperage Control	11
6-5. Frequency Adjustment Control - 60 Hz	12
6-6. Frequency Adjustment Control - 200 Hz	12
SECTION 7 – TIG SHIELDING GASES	13
7-1. Shielding Gases For TIG Welding	13
SECTION 8 – GUIDELINES FOR GTAW WELDING (TIG)	14
8-1. Lift-Arc™ And HF TIG Start Procedures	14
8-2. Torch Movement During Welding	15
8-3. Suggested Inverter Power Source Starting Parameters For Various Aluminum Joints	16
8-4. TIG Welding Techniques	16
8-5. Weld Test	17
SECTION 9 – GTAW TROUBLESHOOTING	18
9-1. Troubleshooting	18

SECTION 1 – SAFETY PRECAUTIONS - READ BEFORE USING

som 2015-09

 Protect yourself and others from injury — read, follow, and save these important safety precautions and operating instructions.

1-1. Symbol Usage



DANGER! – Indicates a hazardous situation which, if not avoided, will result in death or serious injury. The possible hazards are shown in the adjoining symbols or explained in the text.



Indicates a hazardous situation which, if not avoided, could result in death or serious injury. The possible hazards are shown in the adjoining symbols or explained in the text.

NOTICE – Indicates statements not related to personal injury.

 Indicates special instructions.



This group of symbols means Warning! Watch Out! ELECTRIC SHOCK, MOVING PARTS, and HOT PARTS hazards. Consult symbols and related instructions below for necessary actions to avoid the hazards.

1-2. Arc Welding Hazards



The symbols shown below are used throughout this manual to call attention to and identify possible hazards. When you see the symbol, watch out, and follow the related instructions to avoid the hazard. The safety information given below is only a summary of the more complete safety information found in the Safety Standards listed in Section 1-5. Read and follow all Safety Standards.



Only qualified persons should install, operate, maintain, and repair this unit.



During operation, keep everybody, especially children, away.



ELECTRIC SHOCK can kill.

Touching live electrical parts can cause fatal shocks or severe burns. The electrode and work circuit is electrically live whenever the output is on. The input power circuit and machine internal circuits are also live when power is on. In semiautomatic or automatic wire welding, the wire, wire reel, drive roll housing, and all metal parts touching the welding wire are electrically live. Incorrectly installed or improperly grounded equipment is a hazard.

- Do not touch live electrical parts.

- Wear dry, hole-free insulating gloves and body protection.
- Insulate yourself from work and ground using dry insulating mats or covers big enough to prevent any physical contact with the work or ground.
- Do not use AC output in damp areas, if movement is confined, or if there is a danger of falling.
- Use AC output ONLY if required for the welding process.
- If AC output is required, use remote output control if present on unit.
- Additional safety precautions are required when any of the following electrically hazardous conditions are present: in damp locations or while wearing wet clothing; on metal structures such as floors, gratings, or scaffolds; when in cramped positions such as sitting, kneeling, or lying; or when there is a high risk of unavoidable or accidental contact with the workpiece or ground. For these conditions, use the following equipment in order presented: 1) a semiautomatic DC constant voltage (wire) welder, 2) a DC manual (stick) welder, or 3) an AC welder with reduced open-circuit voltage. In most situations, use of a DC, constant voltage wire welder is recommended. And, do not work alone!
- Disconnect input power or stop engine before installing or servicing this equipment. Lockout/tagout input power according to OSHA 29 CFR 1910.147 (see Safety Standards).
- Properly install, ground, and operate this equipment according to its Owner's Manual and national, state, and local codes.

- Always verify the supply ground – check and be sure that input power cord ground wire is properly connected to ground terminal in disconnect box or that cord plug is connected to a properly grounded receptacle outlet.
- When making input connections, attach proper grounding conductor first – double-check connections.
- Keep cords dry, free of oil and grease, and protected from hot metal and sparks.
- Frequently inspect input power cord and ground conductor for damage or bare wiring – replace immediately if damaged – bare wiring can kill.
- Turn off all equipment when not in use.
- Do not use worn, damaged, undersized, or repaired cables.
- Do not drape cables over your body.
- If earth grounding of the workpiece is required, ground it directly with a separate cable.
- Do not touch electrode if you are in contact with the work, ground, or another electrode from a different machine.
- Do not touch electrode holders connected to two welding machines at the same time since double open-circuit voltage will be present.
- Use only well-maintained equipment. Repair or replace damaged parts at once. Maintain unit according to manual.
- Wear a safety harness if working above floor level.
- Keep all panels and covers securely in place.
- Clamp work cable with good metal-to-metal contact to workpiece or worktable as near the weld as practical.
- Insulate work clamp when not connected to workpiece to prevent contact with any metal object.
- Do not connect more than one electrode or work cable to any single weld output terminal. Disconnect cable for process not in use.
- Use GFCI protection when operating auxiliary equipment in damp or wet locations.

SIGNIFICANT DC VOLTAGE exists in inverter welding power sources AFTER removal of input power.

- Turn Off inverter, disconnect input power, and discharge input capacitors according to instructions in Maintenance Section before touching any parts.



HOT PARTS can burn.

- Do not touch hot parts bare handed.
- Allow cooling period before working on equipment.
- To handle hot parts, use proper tools and/or wear heavy, insulated welding gloves and clothing to prevent burns.



FUMES AND GASES can be hazardous.

Welding produces fumes and gases. Breathing these fumes and gases can be hazardous to your health.

- Keep your head out of the fumes. Do not breathe the fumes.
- If inside, ventilate the area and/or use local forced ventilation at the arc to remove welding fumes and gases. The recommended way to determine adequate ventilation is to sample for the composition and quantity of fumes and gases to which personnel are exposed.
- If ventilation is poor, wear an approved air-supplied respirator.
- Read and understand the Safety Data Sheets (SDSs) and the manufacturer's instructions for adhesives, coatings, cleaners, consumables, coolants, degreasers, fluxes, and metals.
- Work in a confined space only if it is well ventilated, or while wearing an air-supplied respirator. Always have a trained watch-person nearby. Welding fumes and gases can displace air and lower the oxygen level causing injury or death. Be sure the breathing air is safe.
- Do not weld in locations near degreasing, cleaning, or spraying operations. The heat and rays of the arc can react with vapors to form highly toxic and irritating gases.
- Do not weld on coated metals, such as galvanized, lead, or cadmium plated steel, unless the coating is removed from the weld area, the area is well ventilated, and while wearing an air-supplied respirator. The coatings and any metals containing these elements can give off toxic fumes if welded.



ARC RAYS can burn eyes and skin.

Arc rays from the welding process produce intense visible and invisible (ultraviolet and infrared) rays that can burn eyes and skin. Sparks fly off from the weld.

- Wear an approved welding helmet fitted with a proper shade of filter lenses to protect your face and eyes from arc rays and sparks when welding or watching (see ANSI Z49.1 and Z87.1 listed in Safety Standards).
- Wear approved safety glasses with side shields under your helmet.
- Use protective screens or barriers to protect others from flash, glare and sparks; warn others not to watch the arc.
- Wear body protection made from durable, flame-resistant material (leather, heavy cotton, wool). Body protection includes oil-free clothing such as leather gloves, heavy shirt, cuffless trousers, high shoes, and a cap.



WELDING can cause fire or explosion.

Welding on closed containers, such as tanks, drums, or pipes, can cause them to blow up. Sparks can fly off from the welding arc. The flying sparks, hot workpiece, and hot equipment can cause fires and burns. Accidental contact of electrode to metal objects can cause sparks, explosion, overheating, or fire. Check and be sure the area is safe before doing any welding.

- Remove all flammables within 35 ft (10.7 m) of the welding arc. If this is not possible, tightly cover them with approved covers.
- Do not weld where flying sparks can strike flammable material.
- Protect yourself and others from flying sparks and hot metal.
- Be alert that welding sparks and hot materials from welding can easily go through small cracks and openings to adjacent areas.
- Watch for fire, and keep a fire extinguisher nearby.
- Be aware that welding on a ceiling, floor, bulkhead, or partition can cause fire on the hidden side.
- Do not weld on containers that have held combustibles, or on closed containers such as tanks, drums, or pipes unless they are properly prepared according to AWS F4.1 and AWS A6.0 (see Safety Standards).
- Do not weld where the atmosphere can contain flammable dust, gas, or liquid vapors (such as gasoline).
- Connect work cable to the work as close to the welding area as practical to prevent welding current from traveling long, possibly unknown paths and causing electric shock, sparks, and fire hazards.
- Do not use welder to thaw frozen pipes.

- Remove stick electrode from holder or cut off welding wire at contact tip when not in use.
- Wear body protection made from durable, flame-resistant material (leather, heavy cotton, wool). Body protection includes oil-free clothing such as leather gloves, heavy shirt, cuffless trousers, high shoes, and a cap.
- Remove any combustibles, such as a butane lighter or matches, from your person before doing any welding.
- After completion of work, inspect area to ensure it is free of sparks, glowing embers, and flames.
- Use only correct fuses or circuit breakers. Do not oversize or bypass them.
- Follow requirements in OSHA 1910.252 (a) (2) (iv) and NFPA 51B for hot work and have a fire watcher and extinguisher nearby.
- Read and understand the Safety Data Sheets (SDSs) and the manufacturer's instructions for adhesives, coatings, cleaners, consumables, coolants, degreasers, fluxes, and metals.

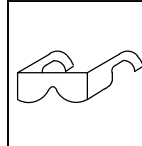

FLYING METAL or DIRT can injure eyes.

- Welding, chipping, wire brushing, and grinding cause sparks and flying metal. As welds cool, they can throw off slag.
- Wear approved safety glasses with side shields even under your welding helmet.



BUILDUP OF GAS can injure or kill.

- Shut off compressed gas supply when not in use.
- Always ventilate confined spaces or use approved air-supplied respirator.

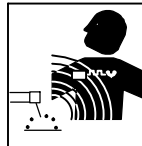

ELECTRIC AND MAGNETIC FIELDS (EMF) can affect Implanted Medical Devices.

- Wearers of Pacemakers and other Implanted Medical Devices should keep away.
- Implanted Medical Device wearers should consult their doctor and the device manufacturer before going near arc welding, spot welding, gouging, plasma arc cutting, or induction heating operations.

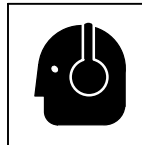

NOISE can damage hearing.

Noise from some processes or equipment can damage hearing.

- Wear approved ear protection if noise level is high.

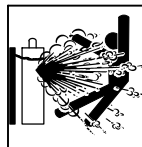

CYLINDERS can explode if damaged.

Compressed gas cylinders contain gas under high pressure. If damaged, a cylinder can explode. Since gas cylinders are normally part of the welding process, be sure to treat them carefully.

- Protect compressed gas cylinders from excessive heat, mechanical shocks, physical damage, slag, open flames, sparks, and arcs.
- Install cylinders in an upright position by securing to a stationary support or cylinder rack to prevent falling or tipping.
- Keep cylinders away from any welding or other electrical circuits.
- Never drape a welding torch over a gas cylinder.
- Never allow a welding electrode to touch any cylinder.
- Never weld on a pressurized cylinder – explosion will result.
- Use only correct compressed gas cylinders, regulators, hoses, and fittings designed for the specific application; maintain them and associated parts in good condition.
- Turn face away from valve outlet when opening cylinder valve. Do not stand in front of or behind the regulator when opening the valve.
- Keep protective cap in place over valve except when cylinder is in use or connected for use.
- Use the right equipment, correct procedures, and sufficient number of persons to lift and move cylinders.
- Read and follow instructions on compressed gas cylinders, associated equipment, and Compressed Gas Association (CGA) publication P-1 listed in Safety Standards.

1-3. Additional Symbols For Installation, Operation, And Maintenance



FIRE OR EXPLOSION hazard.

- Do not install or place unit on, over, or near combustible surfaces.
- Do not install unit near flammables.
- Do not overload building wiring – be sure power supply system is properly sized, rated, and protected to handle this unit.



FALLING EQUIPMENT can injure.

- Use lifting eye to lift unit only, NOT running gear, gas cylinders, or any other accessories.
- Use equipment of adequate capacity to lift and support unit.
- If using lift forks to move unit, be sure forks are long enough to extend beyond opposite side of unit.
- Keep equipment (cables and cords) away from moving vehicles when working from an aerial location.
- Follow the guidelines in the Applications Manual for the Revised NIOSH Lifting Equation (Publication No. 94-110) when manually lifting heavy parts or equipment.

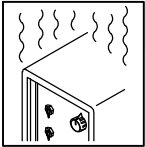

OVERUSE can cause OVERHEATING

- Allow cooling period; follow rated duty cycle.
- Reduce current or reduce duty cycle before starting to weld again.
- Do not block or filter airflow to unit.

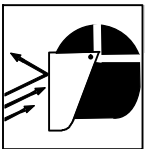

FLYING SPARKS can injure.

- Wear a face shield to protect eyes and face.
- Shape tungsten electrode only on grinder with proper guards in a safe location wearing proper face, hand, and body protection.
- Sparks can cause fires — keep flammables away.



STATIC (ESD) can damage PC boards.

- Put on grounded wrist strap BEFORE handling boards or parts.
- Use proper static-proof bags and boxes to store, move, or ship PC boards.



MOVING PARTS can injure.

- Keep away from moving parts.
- Keep away from pinch points such as drive rolls.



WELDING WIRE can injure.

- Do not press gun trigger until instructed to do so.
- Do not point gun toward any part of the body, other people, or any metal when threading welding wire.

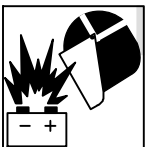

BATTERY EXPLOSION can injure.

- Do not use welder to charge batteries or jump start vehicles unless it has a battery charging feature designed for this purpose.



MOVING PARTS can injure.

- Keep away from moving parts such as fans.
- Keep all doors, panels, covers, and guards closed and securely in place.
- Have only qualified persons remove doors, panels, covers, or guards for maintenance and troubleshooting as necessary.
- Reinstall doors, panels, covers, or guards when maintenance is finished and before reconnecting input power.

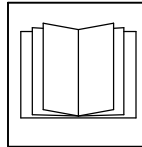

READ INSTRUCTIONS.

- Read and follow all labels and the Owner's Manual carefully before installing, operating, or servicing unit. Read the safety information at the beginning of the manual and in each section.
- Use only genuine replacement parts from the manufacturer.
- Perform installation, maintenance, and service according to the Owner's Manuals, industry standards, and national, state, and local codes.

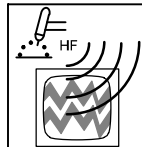

H.F. RADIATION can cause interference.

- High-frequency (H.F.) can interfere with radio navigation, safety services, computers, and communications equipment.
- Have only qualified persons familiar with electronic equipment perform this installation.
- The user is responsible for having a qualified electrician promptly correct any interference problem resulting from the installation.
- If notified by the FCC about interference, stop using the equipment at once.
- Have the installation regularly checked and maintained.
- Keep high-frequency source doors and panels tightly shut, keep spark gaps at correct setting, and use grounding and shielding to minimize the possibility of interference.

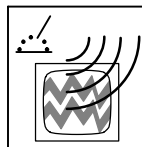

ARC WELDING can cause interference.

- Electromagnetic energy can interfere with sensitive electronic equipment such as computers and computer-driven equipment such as robots.
- Be sure all equipment in the welding area is electromagnetically compatible.
- To reduce possible interference, keep weld cables as short as possible, close together, and down low, such as on the floor.
- Locate welding operation 100 meters from any sensitive electronic equipment.
- Be sure this welding machine is installed and grounded according to this manual.
- If interference still occurs, the user must take extra measures such as moving the welding machine, using shielded cables, using line filters, or shielding the work area.

1-4. California Proposition 65 Warnings

 **Welding or cutting equipment produces fumes or gases which contain chemicals known to the State of California to cause birth defects and, in some cases, cancer. (California Health & Safety Code Section 25249.5 et seq.)**

 **This product contains chemicals, including lead, known to the state of California to cause cancer, birth defects, or other reproductive harm. *Wash hands after use.***

1-5. Principal Safety Standards

Safety in Welding, Cutting, and Allied Processes, ANSI Standard Z49.1, is available as a free download from the American Welding Society at <http://www.aws.org> or purchased from Global Engineering Documents (phone: 1-877-413-5184, website: www.global.ihs.com).

Safe Practices for the Preparation of Containers and Piping for Welding and Cutting, American Welding Society Standard AWS F4.1, from Global Engineering Documents (phone: 1-877-413-5184, website: www.global.ihs.com).

Safe Practices for Welding and Cutting Containers that have Held Combustibles, American Welding Society Standard AWS A6.0, from Global Engineering Documents (phone: 1-877-413-5184, website: www.global.ihs.com).

National Electrical Code, NFPA Standard 70, from National Fire Protection Association, Quincy, MA 02269 (phone: 1-800-344-3555, website: www.nfpa.org and www.sparky.org).

Safe Handling of Compressed Gases in Cylinders, CGA Pamphlet P-1, from Compressed Gas Association, 14501 George Carter Way, Suite 103, Chantilly, VA 20151 (phone: 703-788-2700, website: www.cga-net.com).

Safety in Welding, Cutting, and Allied Processes, CSA Standard W117.2, from Canadian Standards Association, Standards Sales, 5060 Spectrum Way, Suite 100, Mississauga, Ontario, Canada L4W 5N5 (phone: 800-463-6727, website: www.csagroup.org).

Safe Practice For Occupational And Educational Eye And Face Protection, ANSI Standard Z87.1, from American National Standards Institute, 25 West 43rd Street, New York, NY 10036 (phone: 212-642-4900, website: www.ansi.org).

Standard for Fire Prevention During Welding, Cutting, and Other Hot Work, NFPA Standard 51B, from National Fire Protection Association, Quincy, MA 02269 (phone: 1-800-344-3555, website: www.nfpa.org).

OSHA, Occupational Safety and Health Standards for General Industry, Title 29, Code of Federal Regulations (CFR), Part 1910, Subpart Q, and Part 1926, Subpart J, from U.S. Government Printing Office, Superintendent of Documents, P.O. Box 371954, Pittsburgh, PA 15250-7954 (phone: 1-866-512-1800) (there are 10 OSHA Regional Offices—phone for Region 5, Chicago, is 312-353-2220, website: www.osha.gov).

Applications Manual for the Revised NIOSH Lifting Equation, The National Institute for Occupational Safety and Health (NIOSH), 1600 Clifton Rd, Atlanta, GA 30329-4027 (phone: 1-800-232-4636, website: www.cdc.gov/NIOSH).

1-6. EMF Information

Electric current flowing through any conductor causes localized electric and magnetic fields (EMF). The current from arc welding (and allied processes including spot welding, gouging, plasma arc cutting, and induction heating operations) creates an EMF field around the welding circuit. EMF fields can interfere with some medical implants, e.g. pacemakers. Protective measures for persons wearing medical implants have to be taken. For example, restrict access for passers-by or conduct individual risk assessment for welders. All welders should use the following procedures in order to minimize exposure to EMF fields from the welding circuit:

1. Keep cables close together by twisting or taping them, or using a cable cover.
2. Do not place your body between welding cables. Arrange cables to one side and away from the operator.
3. Do not coil or drape cables around your body.

4. Keep head and trunk as far away from the equipment in the welding circuit as possible.
5. Connect work clamp to workpiece as close to the weld as possible.
6. Do not work next to, sit or lean on the welding power source.
7. Do not weld whilst carrying the welding power source or wire feeder.

About Implanted Medical Devices:

Implanted Medical Device wearers should consult their doctor and the device manufacturer before performing or going near arc welding, spot welding, gouging, plasma arc cutting, or induction heating operations. If cleared by your doctor, then following the above procedures is recommended.

SECTION 2 – PRINCIPLES OF GAS TUNGSTEN ARC WELDING (GTAW)

2-1. Process Description

Gas Tungsten Arc Welding (GTAW), also known as tungsten inert gas (TIG) welding is a process that produces an electric arc maintained between a nonconsumable tungsten electrode and the part to be welded. The heat-affected zone, the molten metal, and the tungsten electrode are all shielded from atmospheric contamination by a blanket of inert gas fed through the GTAW torch. Inert gas (usually Argon) is inactive or deficient in active chemical properties. The shielding gas serves to blanket the weld and exclude the active properties in the surrounding air. Inert gases, such as Argon and Helium, do not chemically react or combine with other gases. They pose no odor and are transparent, permitting the the welder maximum visibility of the arc. In some instances Hydrogen gas may be added to enhance travel speeds.

The GTAW process can produce temperatures of up to 35,000° F (19,426° C). The torch contributes heat only to the workpiece. If filler metal is required to make the weld, it may be added manually in the same manner as it is added in the oxyacetylene welding process, or in other situations may be added using a cold wire feeder.

GTAW is used to weld steel, stainless steel, nickel alloys such as Monel® and Inconel®, titanium, aluminum, magnesium, copper, brass, bronze, and even gold. GTAW can also weld dissimilar metals to one another such as copper to brass and stainless steel to mild steel.

Advantages of GTAW welding:

- Concentrated Arc - Permits pinpoint control of heat input to the workpiece resulting in a narrow heat-affected zone.
- No Slag - No requirement for flux with this process; therefore no slag to obscure the welder's vision of the molten weld pool.
- No Sparks or Spatter - No transfer of metal across the arc. No molten globules of spatter to contend with and no sparks produced if material being welded is free of contaminants.
- Little Smoke or Fumes - Compared to other arc-welding processes like stick or flux cored welding, few fumes are produced. However, the base metals being welded may contain coatings or elements such as lead, zinc, copper, and nickel that may produce hazardous fumes. Keep your head and helmet out of any fumes rising off the workpiece. Be sure that proper ventilation is supplied, especially in a confined space.
- Welds more metals and metal alloys than any other arc welding process.
- Good for welding thin material.
- Good for welding dissimilar metals together.

Disadvantages of GTAW welding:

- Slower travel speeds than other processes.
- Lower filler metal deposition rates.
- Hand-eye coordination is a required skill.
- Brighter UV rays than other processes.
- Equipment costs can be higher than with other processes.
- Concentrations of shielding gas may build up and displace oxygen when welding in confined areas – ventilate the area and/or use local forced ventilation at the arc to remove welding fumes and gases. If ventilation is poor, wear an approved air-supplied respirator.

2-2. Selecting A GTAW Power Source

Your choice of a TIG power source is driven by the type and thickness of the material you will weld. This will determine whether you require a machine for all weldable metals except Aluminum and Magnesium (DC) or one that is for all weldable metals (AC/DC).

Items to consider:

- Type of metal to be welded - (Aluminum, Steel, Stainless, etc.).
- Thickness of materials to be welded.
- Package solution that suits the welding application.
- Accessory components that add performance to the system.
- Physical Machine Size – Inverter/Transformer–Rectifier.

2-3. Typical GTAW Welding System

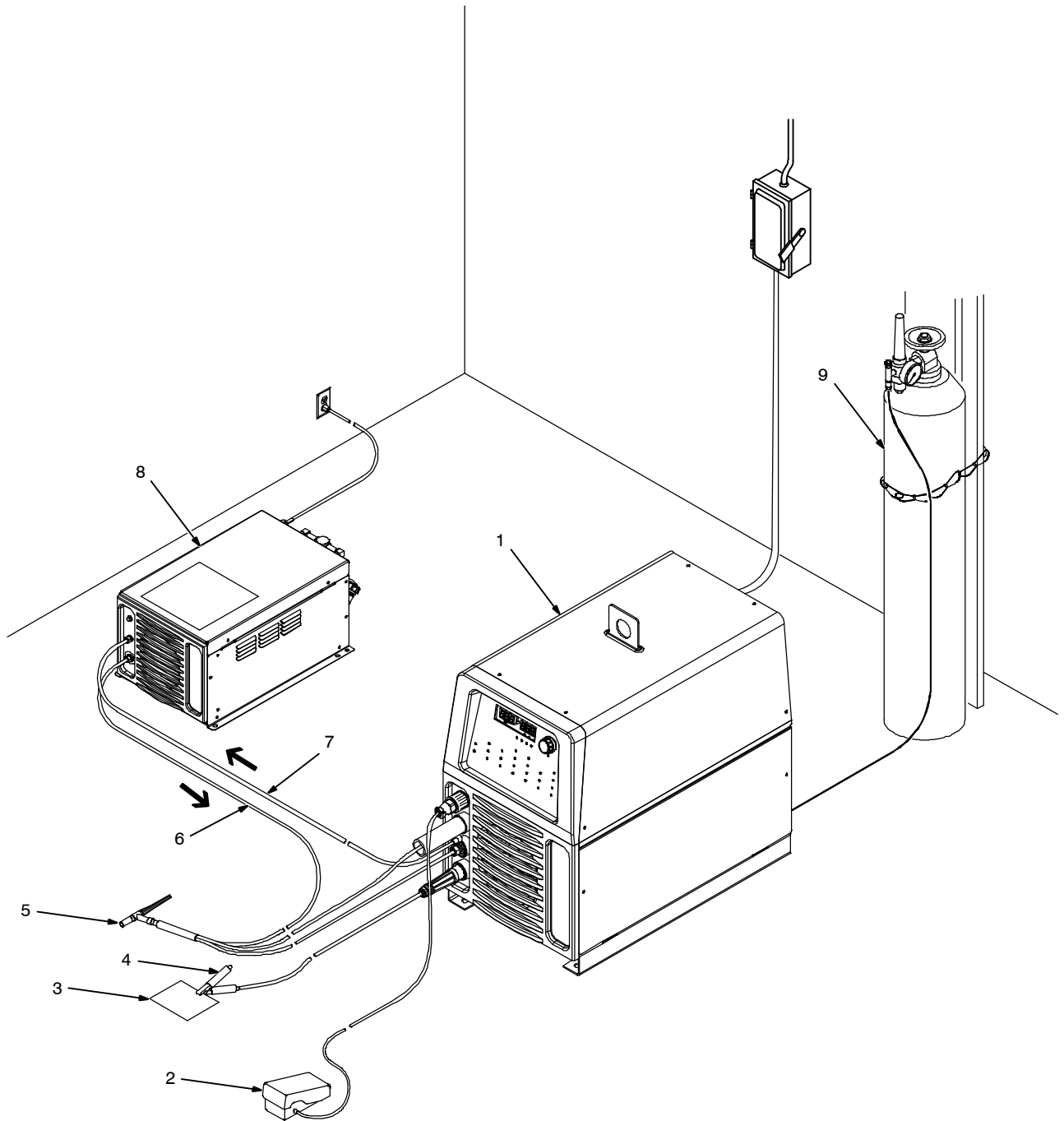

Ref. 804846-A

- 1 Welding Power Source – Constant Current (CC)
- 2 Foot Control
- 3 Workpiece

- 4 Work Clamp
- 5 Torch
- 6 Coolant Out Hose

- 7 Coolant In Hose
- 8 Cooling System
- 9 Shielding Gas

SECTION 3 – GAS TUNGSTEN ARC WELDING (GTAW) PROCEDURE

3-1. Typical GTAW Welding Set-Up

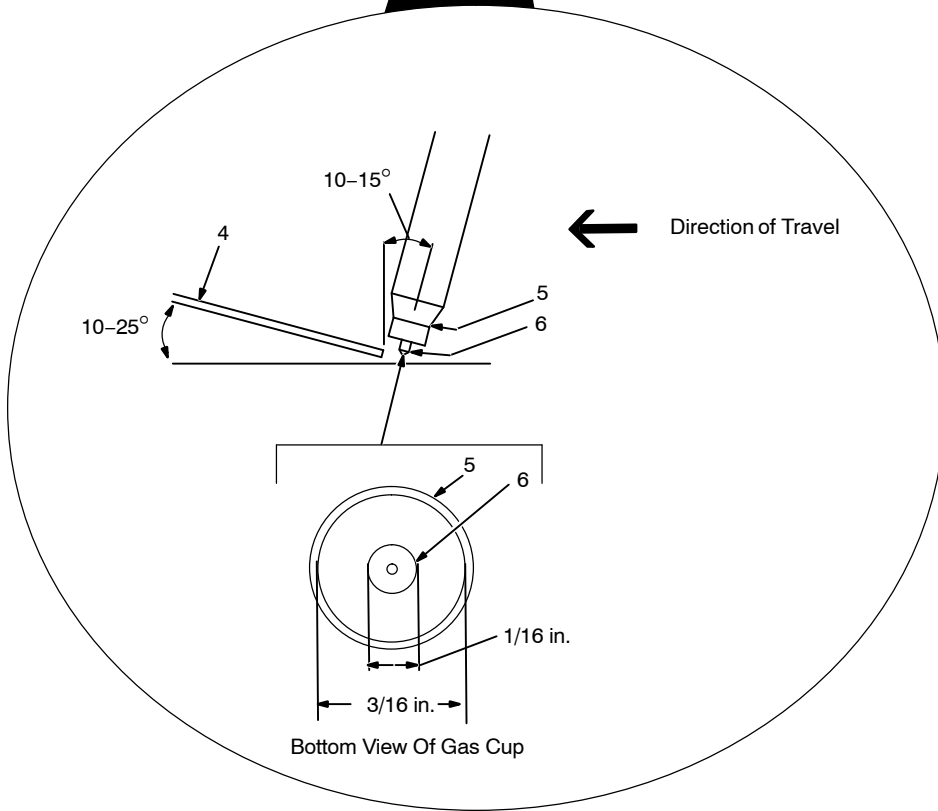
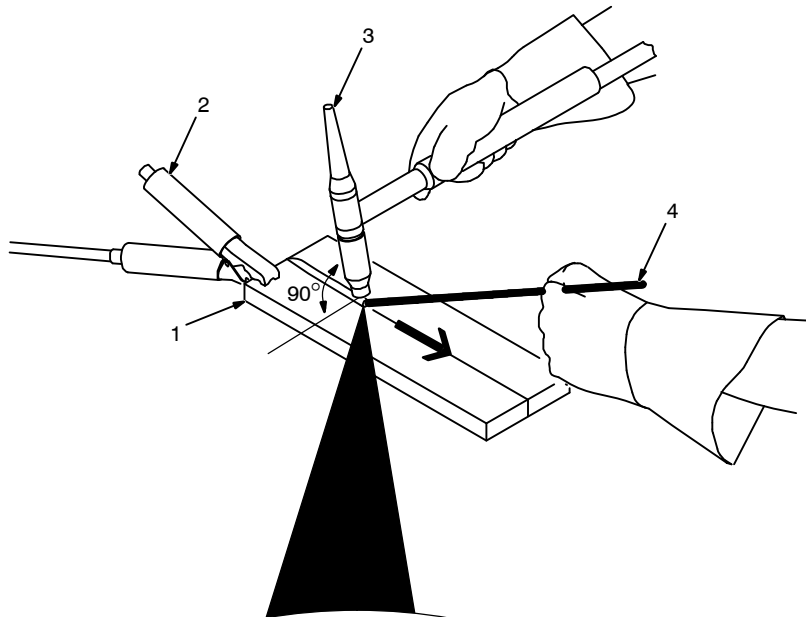

⚠ Grinding the tungsten electrode produces dust and flying sparks which can cause injury and start fires. Use local exhaust (forced ventilation) at the grinder or wear an approved respirator. Read MSDS for safety information. Consider using cerium or lanthanum based tungsten instead of thoriated. Thorium dust contains low-level radioactive material. Properly dispose of grinder dust in an environmentally safe way. Wear proper face, hand, and body protection. Keep flammables away.

- 1 Workpiece
Make sure workpiece is clean before welding.
- 2 Work Clamp
Place as close to the weld as possible.
- 3 Torch
- 4 Filler Rod (If Applicable)
- 5 Gas Cup
- 6 Tungsten Electrode
Select and prepare tungsten according to Section 4.

Guidelines:

The inside diameter of the gas cup should be at least three times the tungsten diameter to provide adequate shielding gas coverage. (For example, if tungsten is 1/16 in. diameter, gas cup should be a minimum of 3/16 in. diameter.)

Tungsten extension is the distance the tungsten extends out gas cup of torch.

The tungsten extension should be no greater than the inside diameter of the gas cup.

Arc length is the distance from the tungsten to the workpiece.

SECTION 4 – SELECTING AND PREPARING A TUNGSTEN FOR DC OR AC WELDING WITH INVERTER MACHINES

gtaw_Inverter_2016-10

   Whenever possible and practical, use DC weld output instead of AC weld output.

4-1. Selecting Tungsten Electrode (Wear Clean Gloves To Prevent Contamination Of Tungsten)



 Not all tungsten electrode manufacturers use the same colors to identify tungsten type. Contact the tungsten electrode manufacturer or reference the product packaging to identify the tungsten you are using.

Electrode Diameter	Amperage Range - Gas Type♦ - Polarity	
	(DCEN) – Argon Direct Current Electrode Negative (For Use With Mild Or Stainless Steel)	AC – Argon Unbalanced Wave (For Use With Aluminum)
2% Ceriated, 1.5% Lanthanum, Or 2% Thorium Alloy Tungsens		
.010 in. (.25 mm)	Up to 15	Up to 15
.020 in. (.50 mm)	5-20	5-20
.040 in. (1 mm)	15-80	15-80
1/16 in. (1.6 mm)	70-150	70-150
3/32 in. (2.4 mm)	150-250	140-235
1/8 in. (3.2 mm)	250-400	225-325
5/32 in. (4.0 mm)	400-500	300-400
3/16 in (4.8 mm)	500-750	400-500
1/4 in. (6.4 mm)	750-1000	500-630

♦ Typical argon shielding gas flow rates are 10 to 25 CFH (cubic feet per hour).

Figures listed are a guide and are a composite of recommendations from American Welding Society (AWS).

4-2. Preparing Tungsten Electrode For DC Electrode Negative (DCEN) Welding Or AC Welding With Inverter Machines

   Grinding the tungsten electrode produces dust and flying sparks which can cause injury and start fires. Use local exhaust (forced ventilation) at the grinder or wear an approved respirator. Read MSDS for safety information. Consider using tungsten containing ceria, lanthana, or yttria instead of thoria. Grinding dust from thoriated electrodes contains low-level radioactive material. Properly dispose of grinder dust in an environmentally safe way. Wear proper face, hand, and body protection. Keep flammables away.

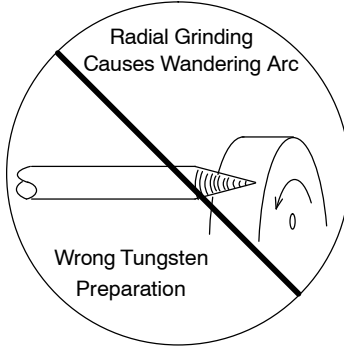

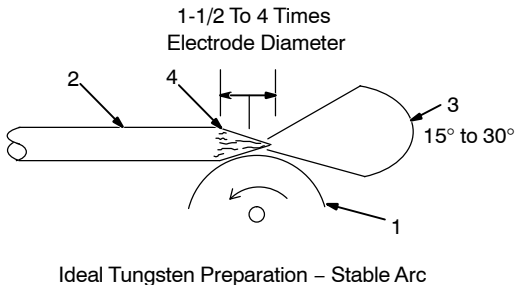

1 Grinding Wheel
Grind end of tungsten on fine grit, hard abrasive wheel before welding. Do not use wheel for other jobs or tungsten can become contaminated causing lower weld quality.

2 Tungsten Electrode
A 2% ceriated tungsten is recommended.

3 Ideal Grind Angle Range: 15° to 30°
 30 degrees is the recommended electrode grind angle.

4 Straight Ground
Grind lengthwise, **not radial**.

SECTION 5 – GTAW WAVEFORMS

- 1 AC Sine Wave
- 2 Weld Sample

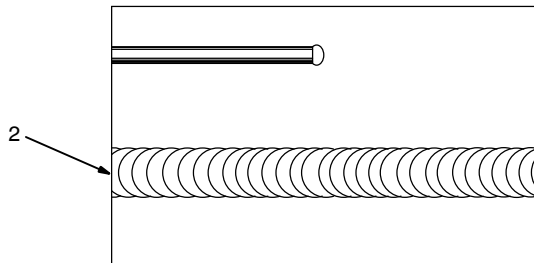
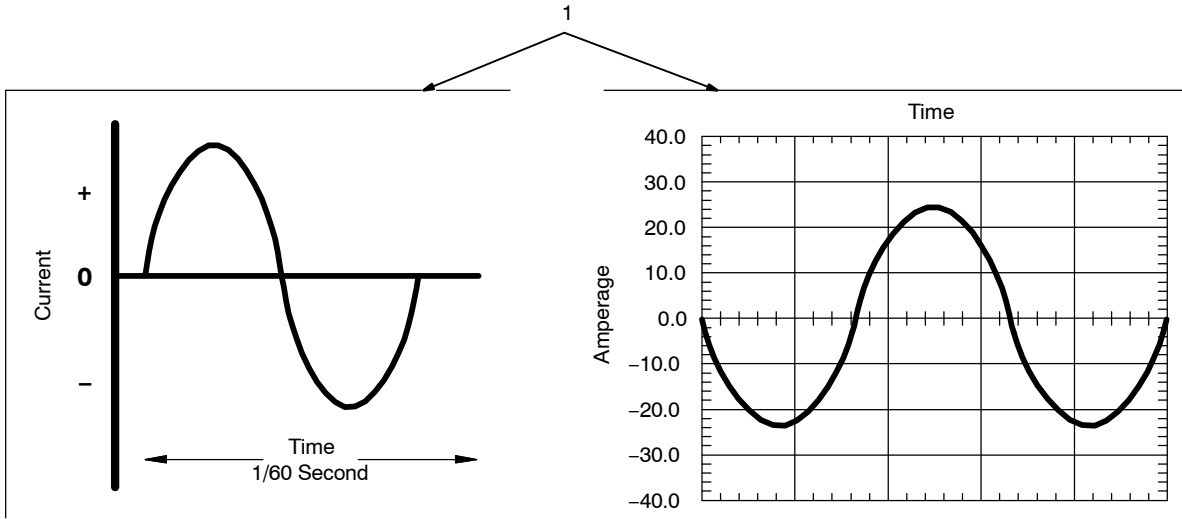

Ref. 805186-A

- 1 Zero Crossover

 *The percentage of time spent in the Zero Crossover Area affects the quality of the welding arc.*

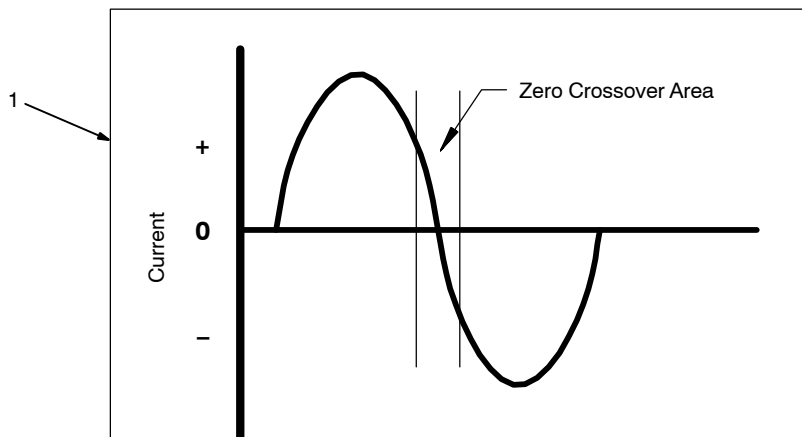

Ref. 805186-A

1 Squarewave Imposed Over Sine Wave

☞ *Less time is spent in zero crossover with squarewave output.*

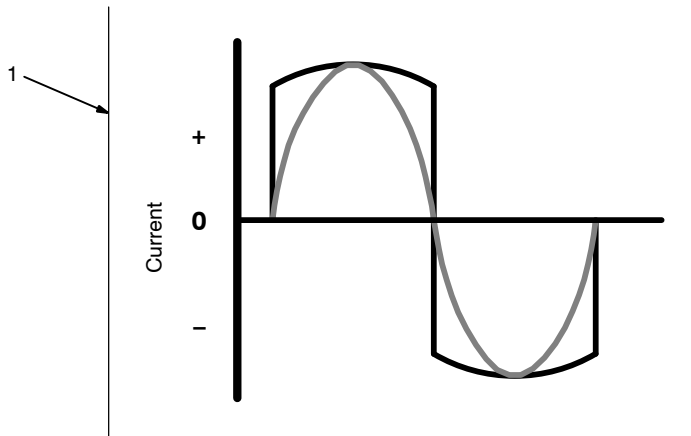

Ref. 805186-A

1 Conventional Squarewave AC
2 Weld Sample

☞ *Faster transition time between electrode positive and electrode negative.*

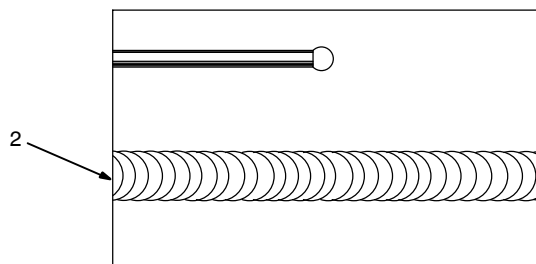
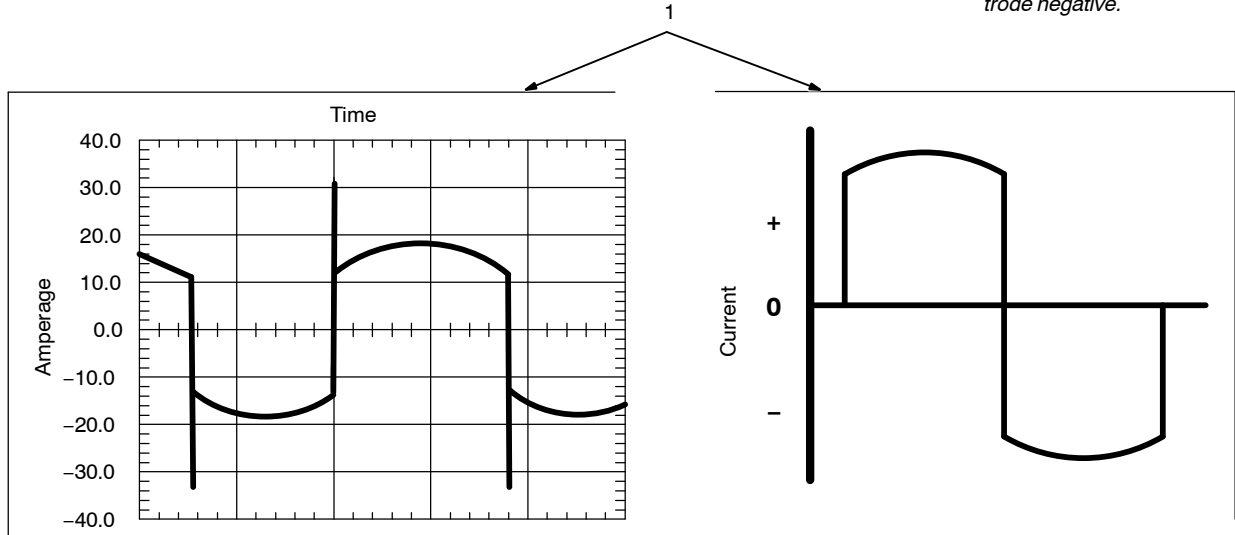

Ref. 805186-A

SECTION 6 – ARC SHAPING CAPABILITIES

6-1. Arc Starting With Different Polarities

Electrode Positive Starting	Electrode Negative Starting
Preheats tungsten	Preferred for Precision DC
Repeatable starting	Repeatable starting
Cleans work on starts	No cleaning on starts
Can damage tungsten tip	No damage to tungsten
Good for AC TIG	Acceptable for AC

☞ Arc shaping capabilities are enhanced by improved balance control, AC frequency control, and independent amperage control.

6-2. Balance Control

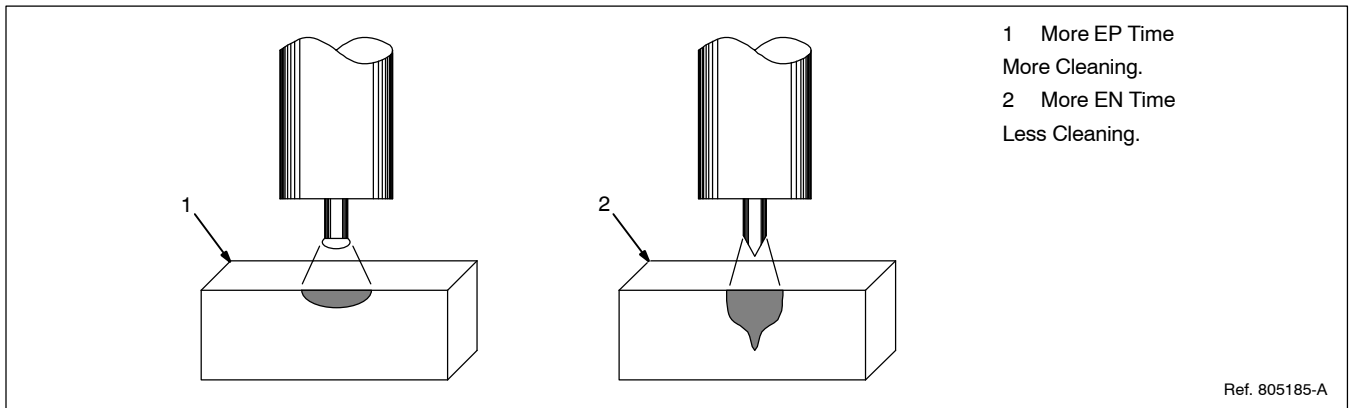

6-3. AC Frequency Adjustment Control

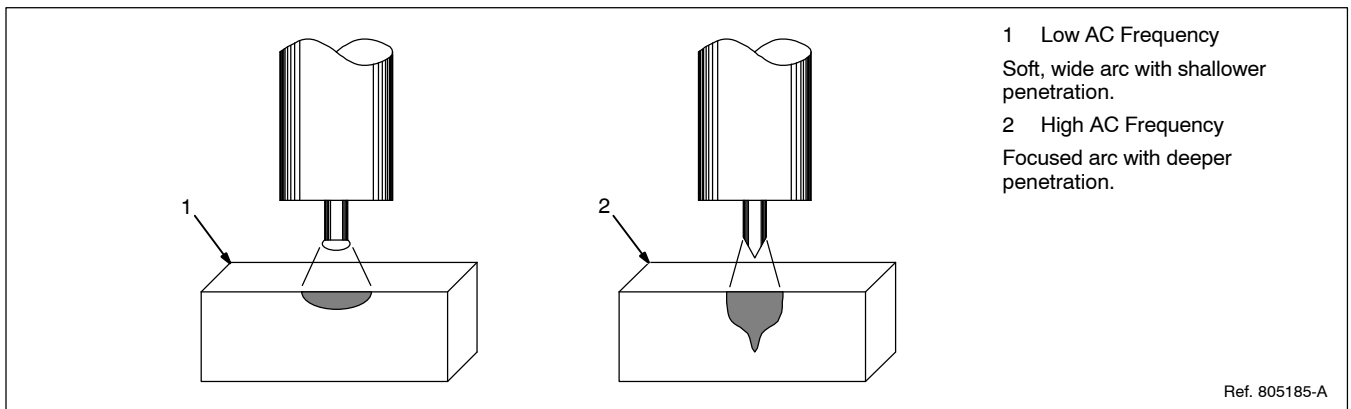

6-4. Independent Amperage Control

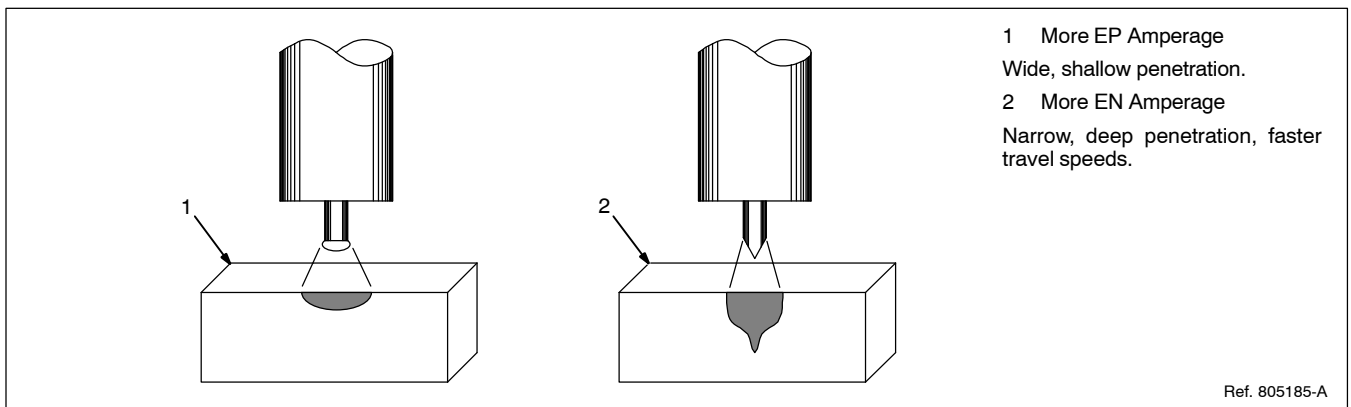

6-5. Frequency Adjustment Control - 60 Hz

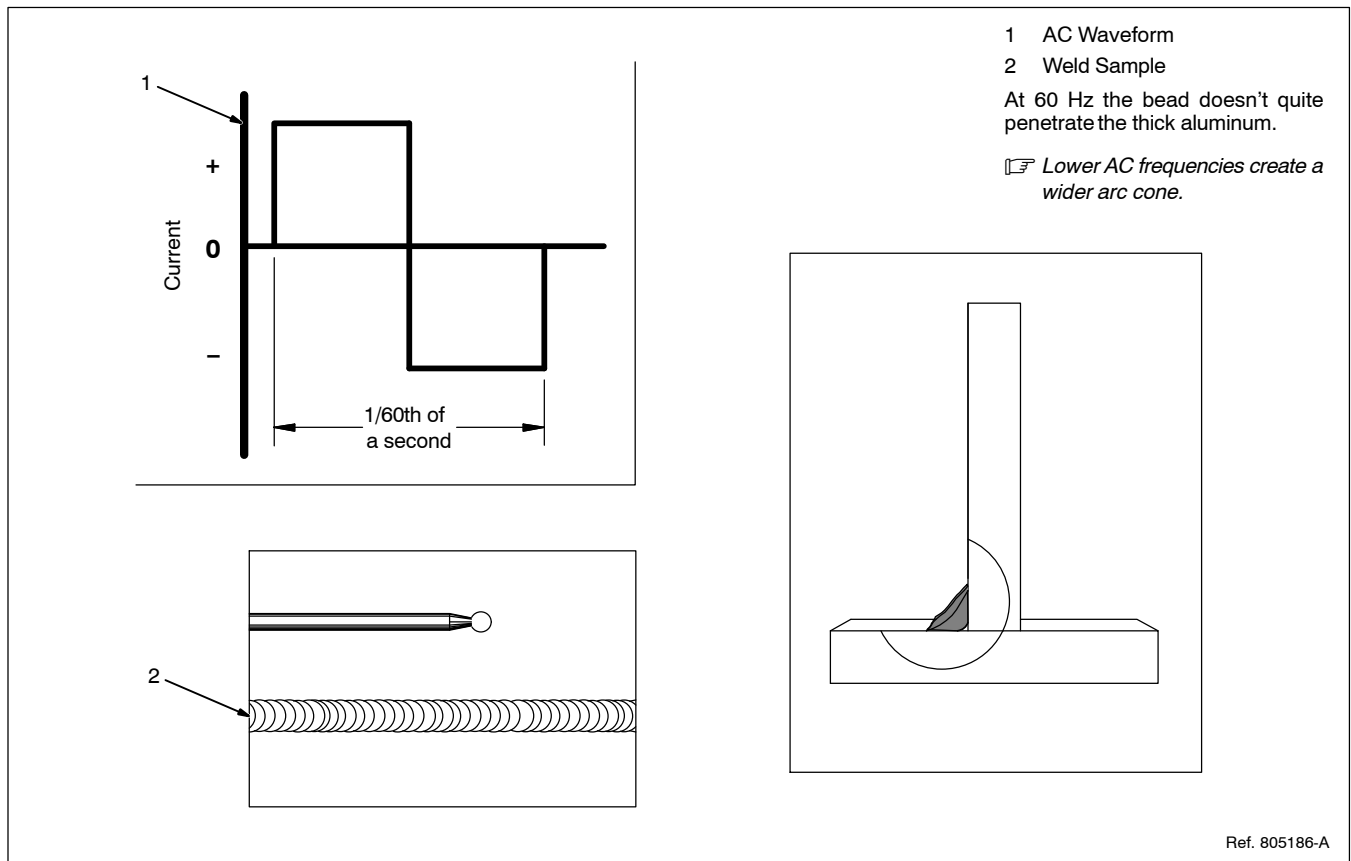

6-6. Frequency Adjustment Control - 200 Hz

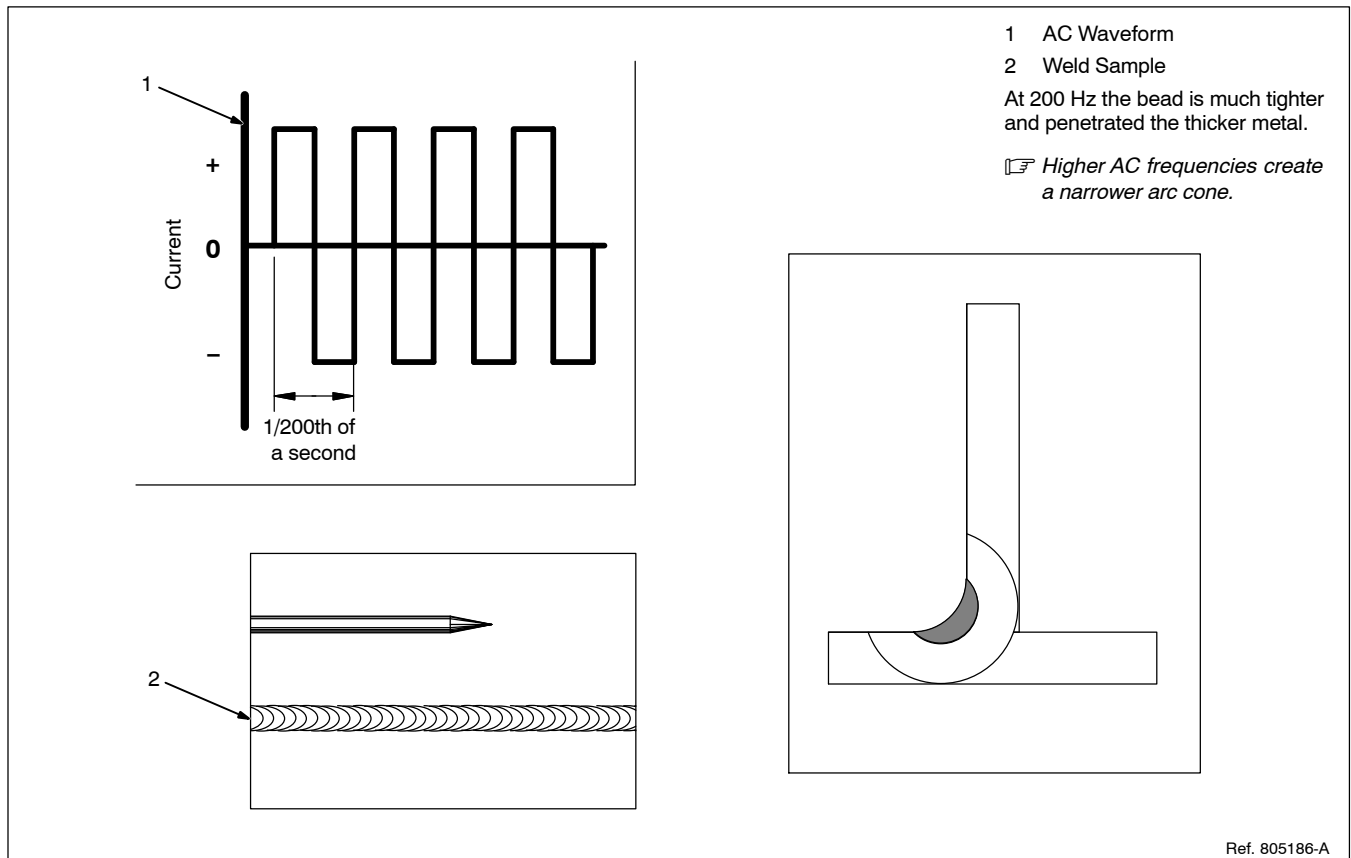

SECTION 7 – TIG SHIELDING GASES

gtaw_Inverter_2007-05

7-1. Shielding Gases For TIG Welding

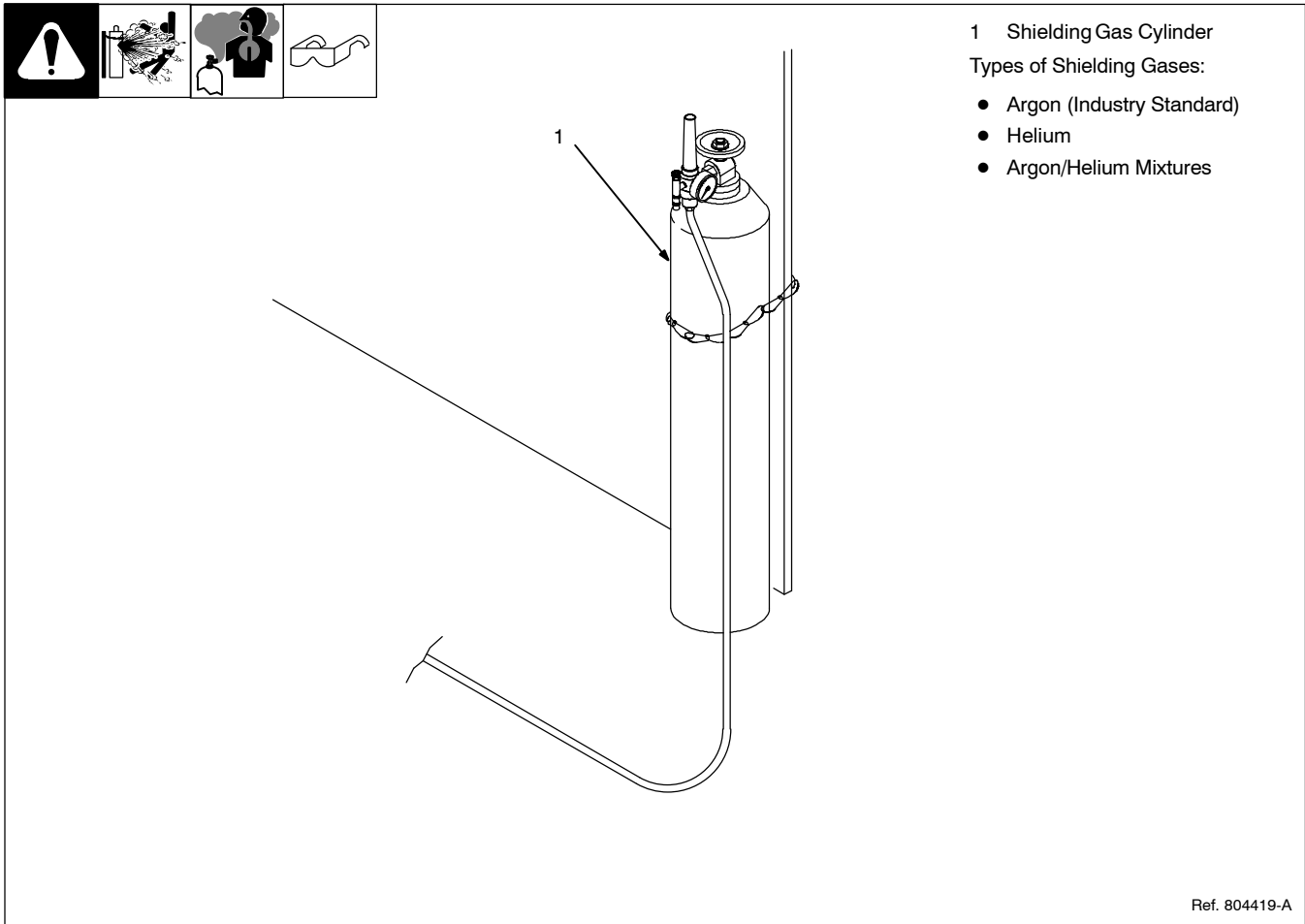

A. Shielding Gas Comparison

CHARACTERISTICS	ARGON	ARGON/HELIUM MIXES	HELIUM
Travel Speed	Reduced travel speeds	Improved travel speeds over 100% Argon	Faster travel speeds
Penetration	Reduced penetration	Improved penetration over 100% Argon	Increased penetration
Cleaning	Good cleaning action	Cleaning properties closer to Argon	Less cleaning action
Arc Starting	Easier arc starting	Improved arc starting over 100% Helium	Difficult arc starting
Arc Stability	Good arc stability	Improved arc stability over 100% Helium	Less low amperage stability
Arc Cone	Focused arc cone	Arc cone shape more focused than w/Helium	Flared arc cone
Arc Voltage	Lower arc voltages	Arc voltages between 100% Argon and Helium	Higher arc voltages
Flow Rate	Lower flow rates 10-30 CFH	Higher flow rates than Argon	Higher flow rates (2 times)
Cost	Lower cost and greater availability	Costs higher than Argon	Higher cost than Argon

SECTION 8 – GUIDELINES FOR GTAW WELDING (TIG)

8-1. Lift-Arc™ And HF TIG Start Procedures

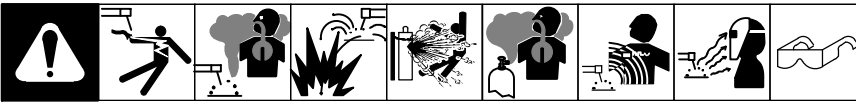

Lift Arc Start Method

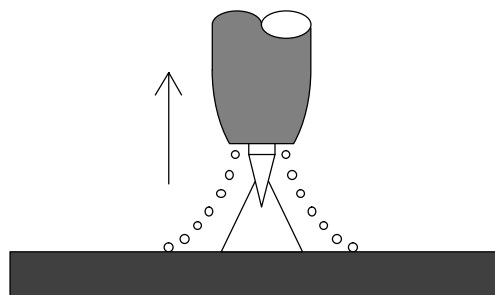
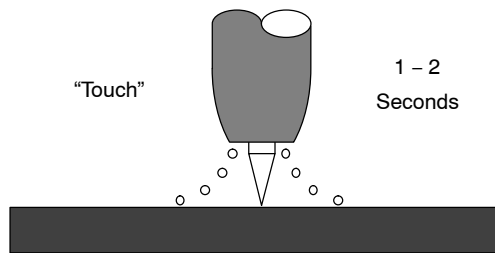
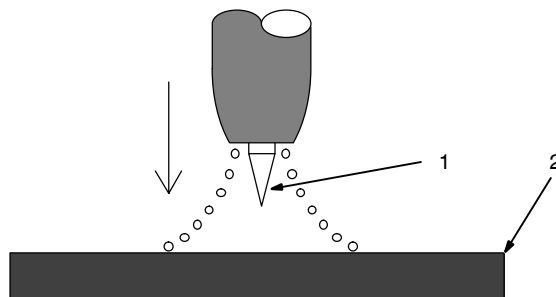

Do NOT Strike Like A Match!

Lift-Arc Start

- 1 TIG Electrode
- 2 Workpiece

Touch tungsten electrode to workpiece at weld start point and enable output and shielding gas with torch trigger, foot control, or hand control. **Hold electrode to workpiece for 1-2 seconds**, and slowly lift electrode. Arc is formed when electrode is lifted.

Normal open-circuit voltage is not present before tungsten electrode touches workpiece; only a low sensing voltage is present between electrode and workpiece. The solid-state output contactor does not energize until after electrode is touching workpiece. This allows electrode to touch workpiece without overheating, sticking, or getting contaminated.

Application:

Lift-Arc is used for the DCEN or AC GTAW process when HF Start method is not permitted, or to replace the scratch method.

HF Start

High frequency turns on to help start arc when output is enabled. High frequency turns off when arc is started, and turns on whenever arc is broken to help restart arc.

☞ Type of power source and output polarity may affect when high frequency turns off after arc is started.

Application:

HF start is used for the DCEN GTAW process when a non-contact arc starting method is required.

8-2. Torch Movement During Welding

Tungsten Without Filler Rod

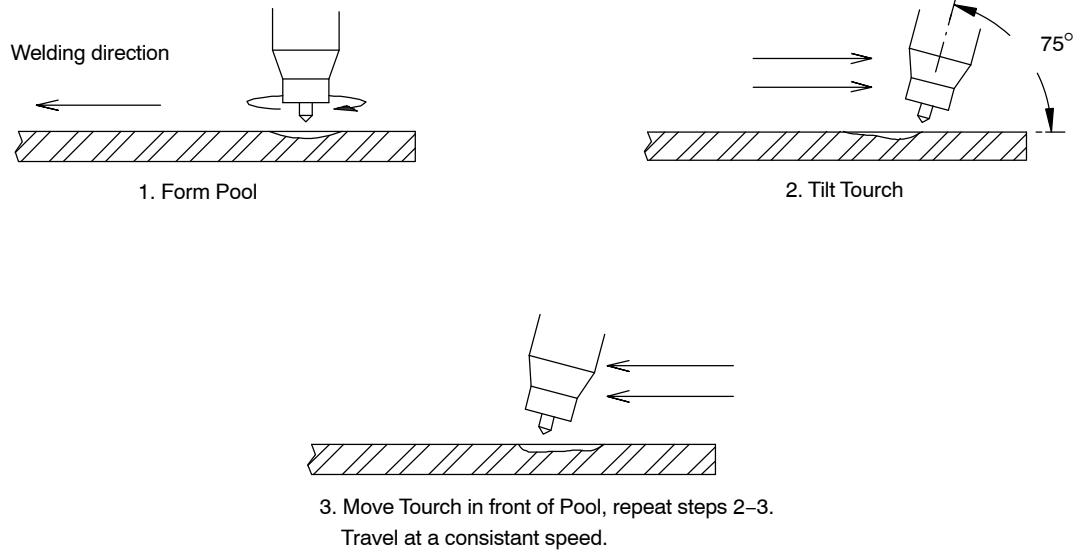

Tungsten With Filler Rod

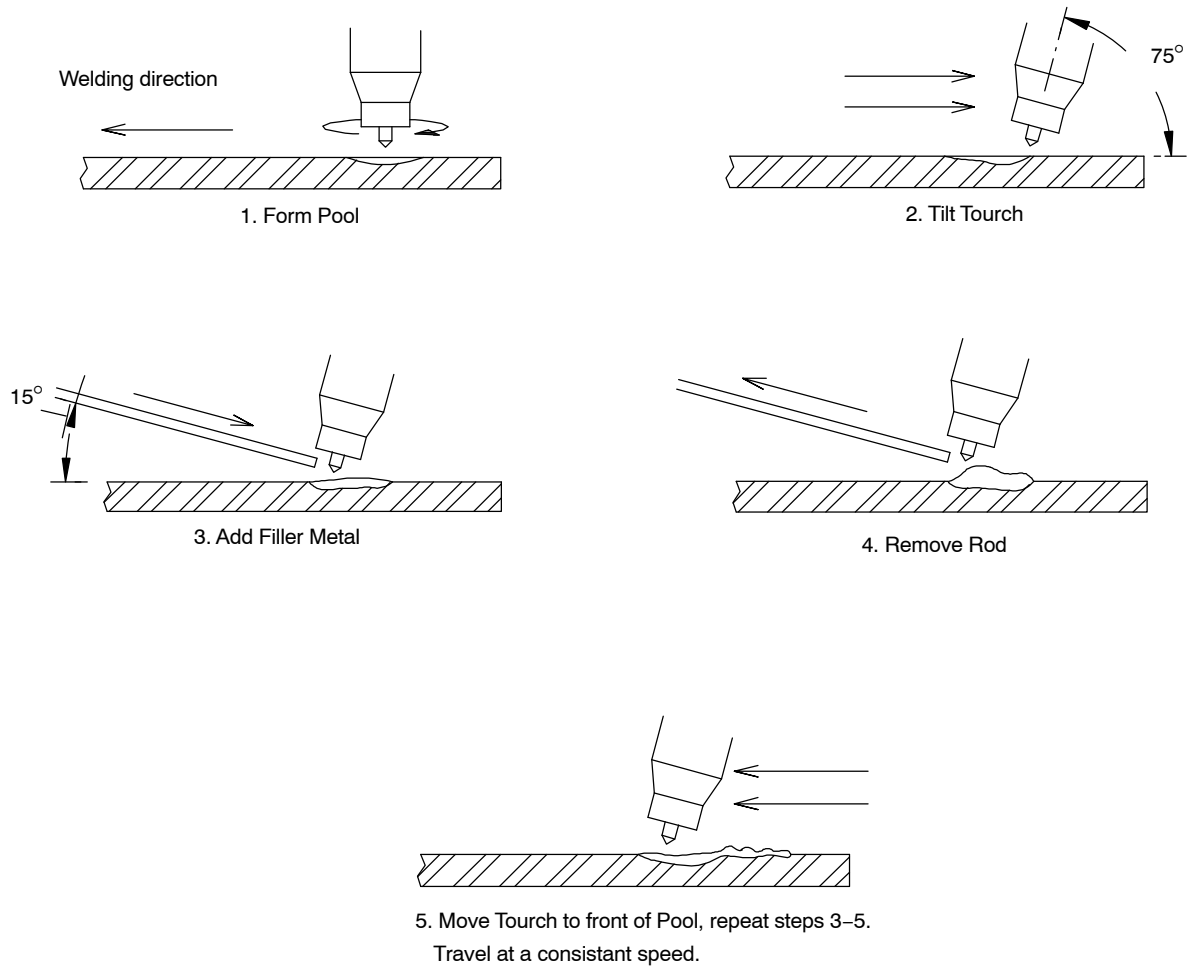

8-3. Suggested Inverter Power Source Starting Parameters For Various Aluminum Joints

Weld Joints	Amperage	Balance	Frequency	Base Material Alloy	Base Material Thickness	Filler Rod Diameter	Filler Alloy	Tungsten Type	Tungsten Diameter	Shielding Gas	Gas Flow
Butt Joint	90-120	65-75%	60-120 Hz	6061	1/8 in.	1/8 in.	5356	2% Ceriated	3/32 in.	Argon	15-20 CFH
T-Joint	100-125	70-75%	100-200 Hz	6061	1/8 in.	1/8 in.	5356	2% Ceriated	3/32 in.	Argon	15-20 CFH
Lap Joint	90-110	70-75%	100-150 Hz	6061	1/8 in.	1/8 in.	5356	2% Ceriated	3/32 in.	Argon	15-20 CFH
Corner Joint	80-90	65-70%	100 Hz	6061	1/8 in.	1/8 in.	5356	2% Ceriated	3/32 in.	Argon	15-20 CFH

8-4. TIG Welding Techniques

Butt Joint

Torch Position For Making a Butt Joint

After learning to start and hold an arc, practice running beads of weld metal on flat plates using a full electrode.

Hold the electrode nearly perpendicular to the work, although tilting it ahead (in the direction of travel) will be helpful.

To produce the best results, hold a short arc, travel at a uniform speed, and feed the electrode downward at a constant rate as it melts.

162003 / S-0792

T-Joint

Torch Position For Making a T-Joint

Hold the torch 70 degrees to the work.

To produce the best results, hold a short arc, travel at a uniform speed, and feed the electrode downward at a constant rate as it melts.

162003 / S-0792

8-4. TIG Welding Techniques (Continued)

Lap Joint

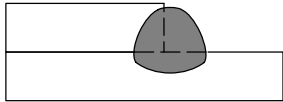

Torch Position For Making a Lap Joint

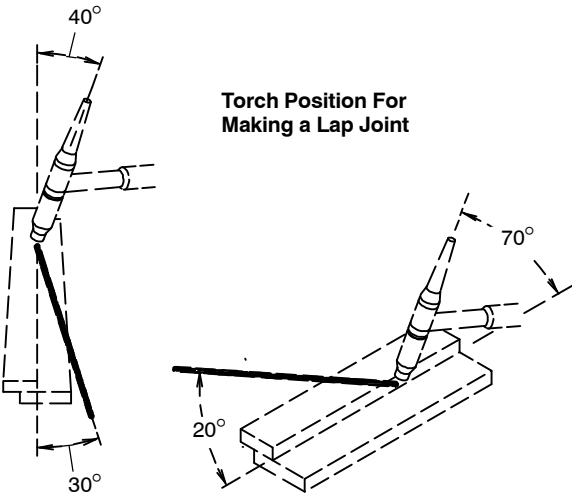

Hold the torch 70 degrees to the work.

To produce the best results, hold a short arc, travel at a uniform speed, and feed the electrode downward at a constant rate as it melts.

162003 / S-0792

Corner Joint

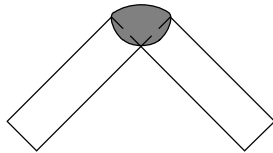

Torch Position For Making a Corner Joint

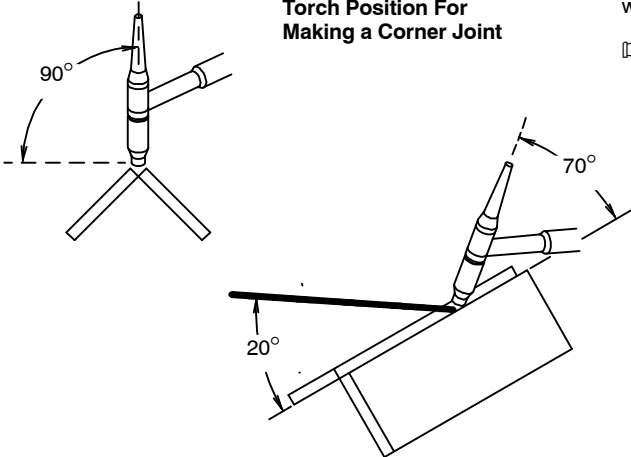

Hold the torch 70 degrees to the work.

To produce the best results, hold a short arc, travel at a uniform speed, and feed the electrode downward at a constant rate as it melts.

162003 / S-0792

8-5. Weld Test

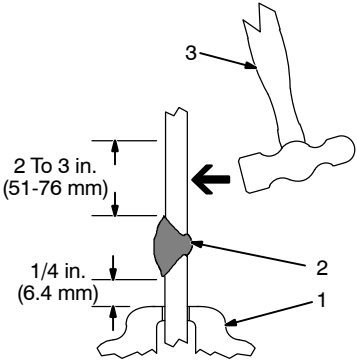

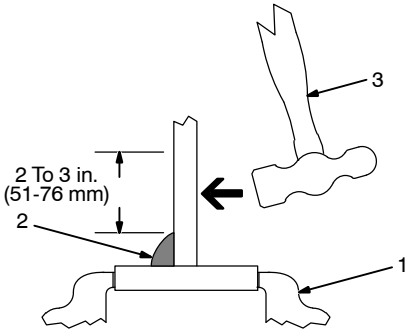

1 Vise
2 Weld Joint
3 Hammer

Strike the weld joint in the direction shown. A good weld bends over but does not break. If the weld breaks, examine it to determine

the cause.

If the weld is porous (many holes), the arc length was probably too long.

If the weld contains bits of slag, the arc may have been too long or the electrode was moved incorrectly which allowed molten slag to be trapped in the weld. This may

happen on a V-groove joint made in several layers and calls for additional cleaning between layers.

If the original beveled surface is visible the material was not fully melted which is often caused by insufficient heat or too fast a travel speed.

S-0057-B

SECTION 9 – GTAW TROUBLESHOOTING

9-1. Troubleshooting



Problem: Burning Through Tungsten Fast	
Probable Causes	Remedy
Inadequate gas flow.	Check to be sure hose, gas valve, and torch are not restricted or the tank is not out of gas. Gas flow should typically be set at 10 to 25 CFH.
Operation on electrode positive (DCEP).	Switch to electrode negative (DCEN).
Improper size tungsten for current used.	Change tungsten - General purpose tungsten size is 3/32 in. diameter at a maximum of 235 amps.
Excessive heating in torch body.	Air-cooled torches get very warm. If using a water-cooled torch, check to make sure circulator is turned on then check coolant flow. Coolant flow may be restricted or coolant may be low.
Tungsten oxidation during cooling.	Keep shielding gas flowing 10-15 seconds after arc stoppage (one second for each 10 amps of weld current).
Use of gas containing oxygen or CO ₂ .	Use argon gas 100 percent.
Tungsten melting back into cup (AC).	If using pure tungsten, change to ceriated or lanthanated. If machine has Balance Control, adjust setting towards Max Penetration (70-90 percent).
	Increase Tungsten size -Tungsten diameter may be too small for the amount of current being used.
Problem: Tungsten Contamination	
Probable Causes	Remedy
Tungsten melting into weld puddle.	Use less current or larger tungsten.
	Use ceriated (AC, DC), thoriated (DC), or lanthanated tungsten.
Touching tungsten to weld puddle.	Keep tungsten from contacting weld puddle. Raise the torch so that the tungsten is off of the work piece 1/16 to 1/8in.
Problem: Shielding Gas	
Probable Causes	Remedy
Inadequate or too much gas flow or wrong gas type.	Check flow rate (10 to 25 CFH) and gas type.
Problem: High Frequency Present - No Arc Power	
Probable Causes	Remedy
Incomplete weld circuit.	Check work connection. Check all cable connections.
No shielding gas.	Check for gas flow at end of torch.
	Check for empty cylinder or closed shut-off valve. Gas flow should typically be set at 10 to 25 CFH.
Problem: Porosity and Poor Weld Bead Color	
Probable Causes	Remedy
Condensation on base metal.	Line should be purged with Argon for a few minutes. Remove all condensation from base metal before welding. Metals stored in cold temperatures will condensate when exposed to warm temperatures.
Loose fittings in torch or hoses.	Tighten fittings on torch and all hoses.
Inadequate or too much gas flow.	Adjust flow rate as necessary. Gas flow should typically be set at 10 to 25 CFH.
Defective gas hose or loose connection.	Replace gas hose and check connections for leaks, cuts, or pin holes.

Probable Causes	Remedy
Contaminated or improper filler metal.	Check filler metal type. Remove all grease, oil, or moisture from filler metal.
Problem: Porosity and Poor Weld Bead Color (Continued)	
Probable Causes	Remedy
Base metal is contaminated.	Remove paint, grease, oil, and dirt (including) mill scale from base metal.
Problem: Yellow Powder or Smoke on Cup – Tungsten Discolor	
Probable Causes	Remedy
Shielding gas flow rate too low.	Increase flow rate. Gas flow should typically be set at 10 to 25 CFH.
Incorrect shielding gas or mixture.	Use argon gas.
Inadequate post flow.	Increase post flow time. Set at 10 to 15 seconds.
Improper tungsten size or cup size.	Match tungsten size and cup size to joint being welded. General purpose tungsten size is 3/32 in. diameter and 8 cup.
Tungsten contamination.	Keep tungsten from contacting weld puddle. Raise the torch so that the tungsten is off of the work piece 1/8 to 1/4 in.
Problem: Unstable Arc While AC Welding	
Probable Causes	Remedy
Excessive rectification in arc.	Increase travel speed. Increase balance control toward Max Penetration. Add filler metal.
Improper shielding gas.	Change shielding gas - In some cases, when welding on 3/8 to 1/2 in. thick aluminum, Argon/Helium is used.
Incorrect arc length.	Use correct arc length. Adjust the torch so that the tungsten is off of the work piece 1/8 to 1/4 in.
Tungsten is contaminated.	Remove 1/2 in. of contaminated tungsten and repoint tungsten.
Base metal is contaminated.	Remove paint, grease, oil, and dirt (including mill scale) from base metal.
Frequency set too low.	On welders with adjustable AC frequency, increase frequency to give proper arc stability and directional control. 100 to 180 Hertz is acceptable, 120 Hz is recommended.
Improperly prepared tungsten	With Squarewave and inverter machines, use pointed tungsten. Point will eventually round off after welding.
Problem: Unstable Arc While DC Welding	
Probable Causes	Remedy
Weld circuit polarity is incorrect.	Check polarity switch on welder. Select DCEN (Direct Current Electrode Negative).
Tungsten is contaminated.	Remove 1/2 in. of contaminated tungsten and repoint tungsten.
Arc too long.	Shorten arc length. Lower torch so that the tungsten is off of the work piece no more than 1/16 to 1/8 in. Check tungsten type or size.
Base metal is contaminated.	Remove paint, grease, oil, and dirt (including mill scale) from base metal.
Problem: Arc Wanders While DC Welding	
Probable Causes	Remedy
Improper arc length/tungsten in poor condition.	Lower the torch so that the tungsten is off of the work piece 1/16 to 1/8 in. Clean and sharpen tungsten. Check tungsten type or size.
Improperly prepared tungsten.	Grind marks should run lengthwise with tungsten, not circular. Use proper grinding method and wheel.
Light gray frosted appearance on end of tungsten.	Remove 1/2 in. of tungsten and repoint tungsten.
Improper gas flow.	Gas flow should typically be set at 10 to 25 CFH.



Owner's Record

Please complete and retain with your personal records.

Model Name

Serial/Style Number

Purchase Date

(Date which equipment was delivered to original customer.)

Distributor

Address

City

State

Zip



For Service

Contact a DISTRIBUTOR or SERVICE AGENCY near you.

Always provide Model Name and Serial/Style Number.

Contact your Distributor for:

Welding Supplies and Consumables

Options and Accessories

Personal Safety Equipment

Service and Repair

Replacement Parts

Training (Schools, Videos, Books)

Technical Manuals (Servicing Information and Parts)

Circuit Diagrams

Welding Process Handbooks

To locate a Distributor or Service Agency visit www.millerwelds.com or call 1-800-4-A-Miller

Contact the Delivering Carrier to:

File a claim for loss or damage during shipment.

For assistance in filing or settling claims, contact your distributor and/or equipment manufacturer's Transportation Department.

Miller Electric Mfg. Co.

An Illinois Tool Works Company
1635 West Spencer Street
Appleton, WI 54914 USA

International Headquarters—USA

USA Phone: 920-735-4505 Auto-Attended
USA & Canada FAX: 920-735-4134
International FAX: 920-735-4125

For International Locations Visit
www.MillerWelds.com

